

REV:	ECO:	DESCRIPTION:	DWN:	DATE:	CHK:
A		PRODUCTION RELEASE	T.A.P.	9/18/02	
B	#3296	REVISIONS REMOVED FROM B.O.M.	T.A.P.	6/3/03	
C	#3436	DIAGONAL UPDATED TO $\phi 21\text{mm}$	T.A.P.	2/5/04	

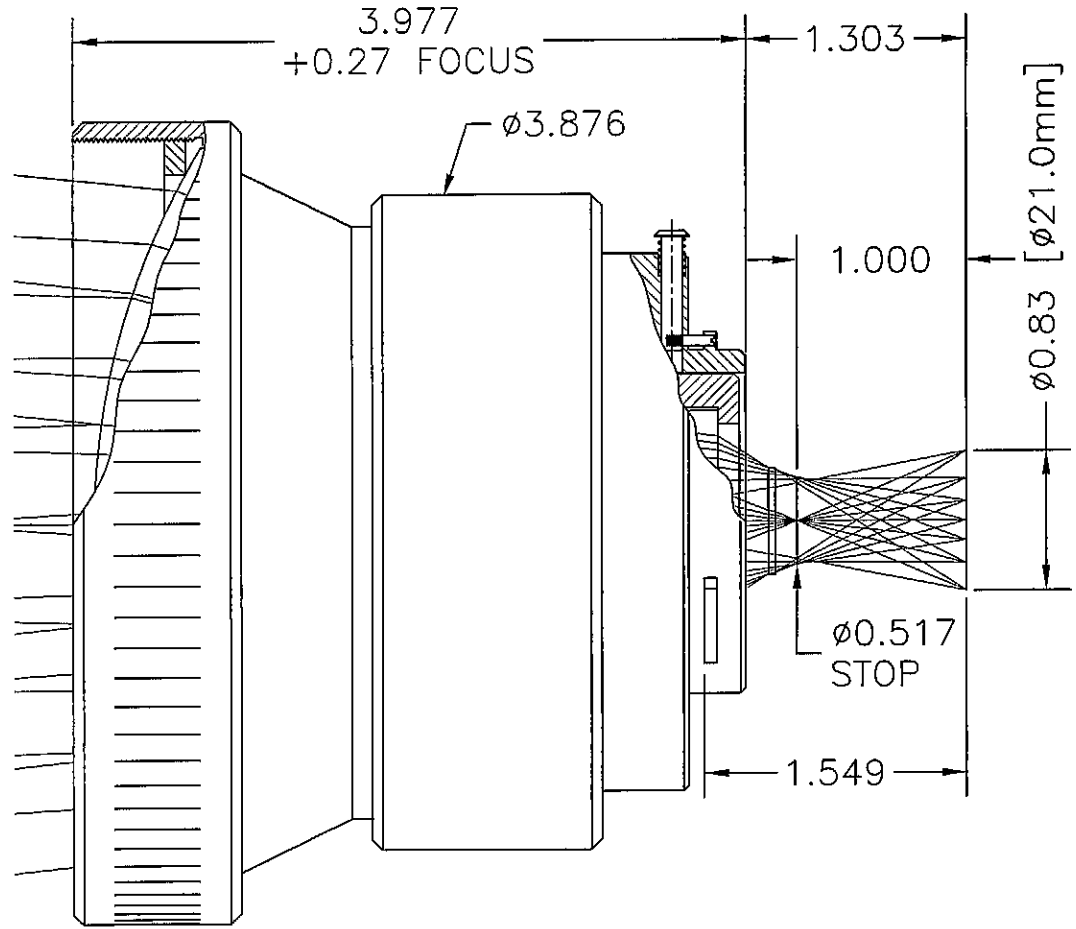
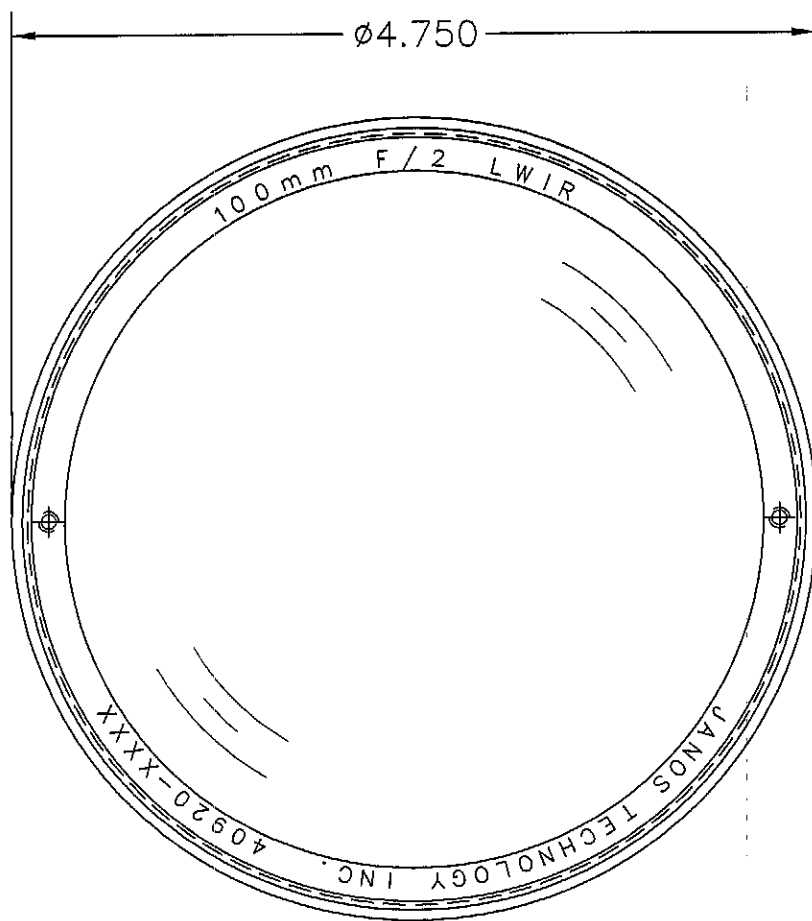

**PROPRIETARY:**

THIS DOCUMENT CONTAINS INFORMATION WHICH IS PROPRIETARY AND IS THE PROPERTY OF JANOS TECHNOLOGY INC. AND MAY NOT BE USED, REPRODUCED, OR DISCLOSED IN ANY MANNER WITHOUT THE EXPRESSED WRITTEN PERMISSION OF JANOS TECHNOLOGY INC.

UNLESS OTHERWISE SPECIFIED DIMENSIONS ARE IN INCHES METRIC EQUIVALENT IN BRACKETS [MM]

ANG.	2 PL	3 PL	HOLES
$\pm X/X'$	$\pm X.XXX$	$\pm X.XXX$	$\pm X.XXX$
DO NOT SCALE DRAWING			
DRAWN:	T.A.P.	DATE:	9/16/02
CHECK:	G.M.L.	DATE:	2/5/04
ENGINEER:		DATE:	
APPROVED:		DATE:	



1068 GRAFTON ROAD, ROUTE 35  
TOWNSHEND, VT 05353 U.S.A.

TITLE: 100mm F/2 LWIR STANDARD ENGRAVING		
SIZE: A	DRAWING NUMBER: 40920-AA1	REVISION: C
SCALE: N.T.S.	FSCM: 8N558	SHEET: 1 OF 2