

REVISIONS				
REV.	ECO	DESCRIPTION	DATE	APPROVED
B	6936	ADDED THREAD INFO	5/5/2021	SCV
C	6968	CHANGING TABLE VALUES	10/27/2021	KKY
D	7134	SEE ECO	5/2/2023	KKY

THREAD ON LENS
 \varnothing 2.313-36 UNS-2A
 MAJOR 2.3118/2.3063
 PITCH 2.2937/2.2896
 MINOR 2.2787/2.2702

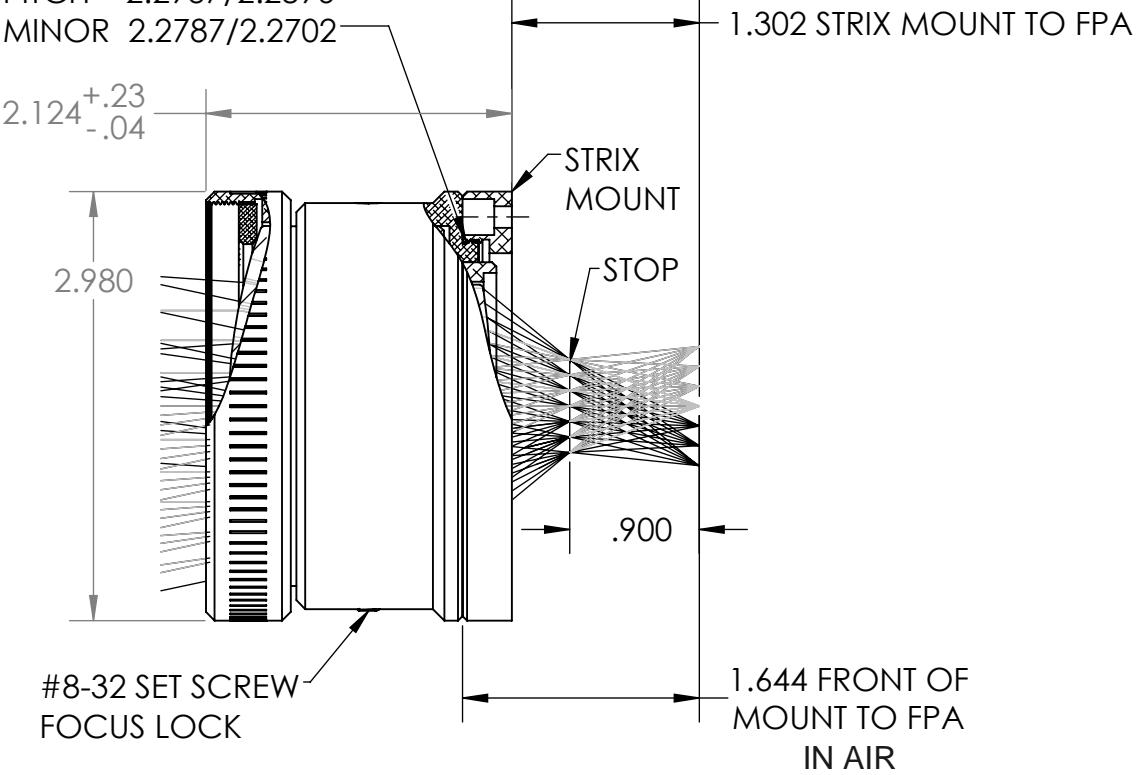

40482-AA1	
FOCAL LENGTH	50mm
CIRCULAR FOV	23°
IMAGE DIAGONAL	21mm
WAVELENGTH	7-14 μ m
F#	1.4
ATHERMAL	NO
INTERFACE	2.313-36 UNS-2A
WEIGHT	<.4kg

PROJECTION: THIRD ANGLE

PROPRIETARY AND CONFIDENTIAL

THIS DOCUMENT CONTAINS INFORMATION WHICH IS PROPRIETARY AND IS THE PROPERTY OF JANOS TECHNOLOGY INC. AND MAY NOT BE USED, REPRODUCED, OR DISCLOSED IN ANY MANNER WITHOUT THE EXPRESSED WRITTEN PERMISSION OF JANOS TECHNOLOGY INC.

UNLESS OTHERWISE SPECIFIED: DIMENSIONS ARE IN INCHES METRIC EQUIVALENTS IN BRACKETS [mm]

ANG.	X.XX	X.XXX	X.XXXX
$\pm 1/2^\circ$	± 0.010	± 0.005	$+0.0005$ -0.0000
DRAWN	JDF	3-17-20	
CHECKED	<i>DAM</i>	5/11/23	
ENG APPR.			
MFG APPR.			
Q.A.			

55 BLACK BROOK ROAD, KEENE, NH 03431 U.S.A.

TITLE: STRIX SERIES
50 mm LWIR -JANOS

SIZE	DWG. NO.	REV
A	40482-ICD	D

SCALE: 3:4 CAGE: 66810 SHEET 1 OF 1