

REVISIONS				
REV.	ECO	DESCRIPTION	DATE	APPROVED
A	6823	ENGINEERING RELEASE	2/13/2020	DAM
B	6936	ADD UPDATED THREAD CALLOUT	5/5/21	SCV
C	7134	SEE ECO	5/2/23	KKY

THREAD ON LENS
 2.313-36 UNS-2A
 MAJOR 2.3118/2.3063
 PITCH 2.2937/2.2896
 MINOR 2.2787/2.2702

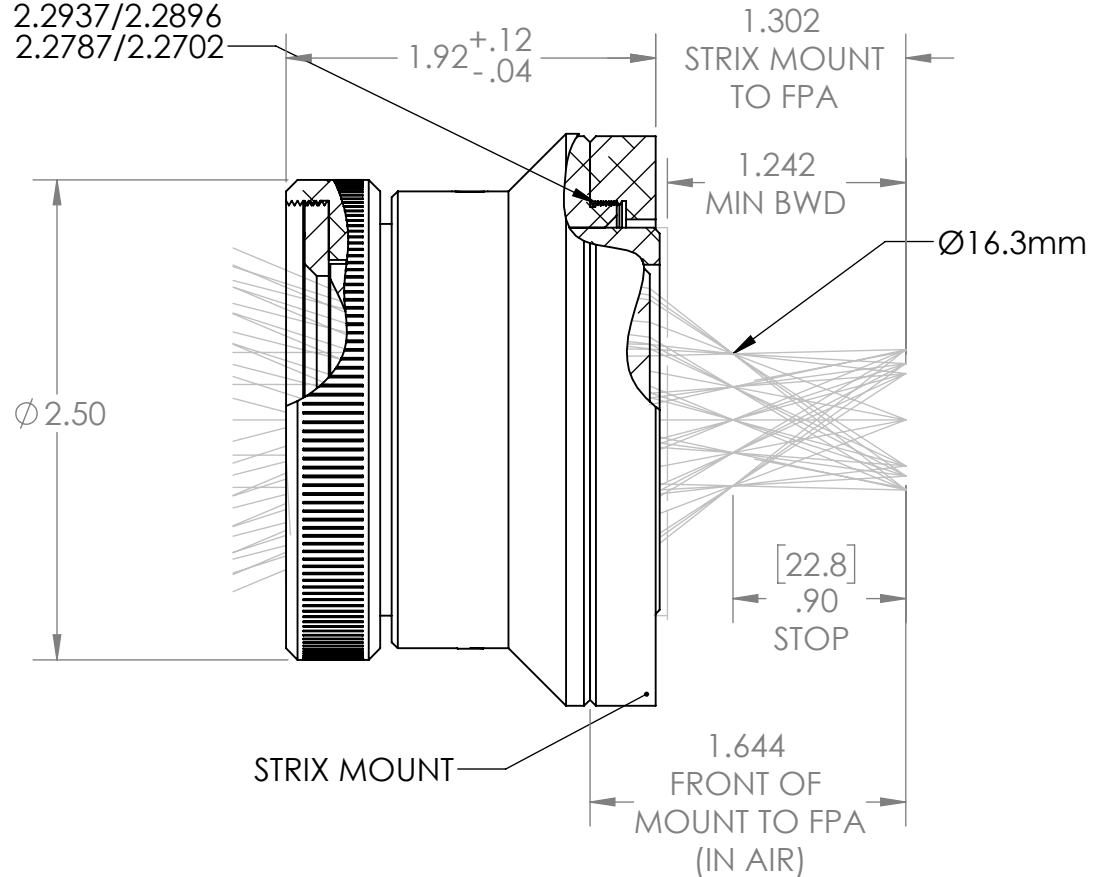

40479-AA1	
FOCAL LENGTH	25mm
FOV (CIRCULAR)	45°
IMAGE DIAG	21mm
WAVELENGTH	7-14µm
F #	1.4
ATHERMAL	NO
INTERFACE CAMERA	2.313-36 UNS-2A
WEIGHT	< .4kg

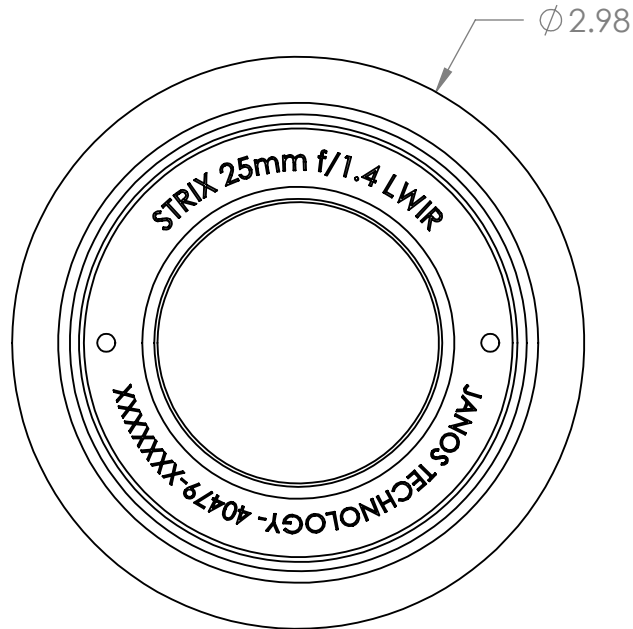
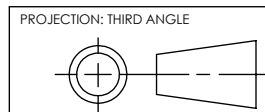

PROPRIETARY AND CONFIDENTIAL

THIS DOCUMENT CONTAINS
 INFORMATION WHICH IS PROPRIETARY
 AND IS THE PROPERTY OF JANOS
 TECHNOLOGY INC. AND MAY NOT BE
 USED, REPRODUCED, OR DISCLOSED IN
 ANY MANNER WITHOUT THE EXPRESSED
 WRITTEN PERMISSION OF JANOS
 TECHNOLOGY INC.

UNLESS OTHERWISE SPECIFIED:
 DIMENSIONS ARE IN INCHES
 METRIC EQUIVALENTS IN
 BRACKETS [mm]

ANG.	X.XX	X.XXX	X.XXXX
±1°	±0.010	±0.008	±0.0005
DRAWN	DAM	2/13/20	
CHECKED	DAM	5/11/23	
ENG APPR.			
MFG APPR.			
Q.A.			



55 BLACK BROOK ROAD, KEENE, NH 03431 U.S.A.

TITLE: STRIX SERIES 25mm f/1.4 7-14µm - JANOS

SIZE	DWG. NO.	REV
A	40479-ICD	C

SCALE: 1:1 CAGE: 66810 SHEET 1 OF 1